

CmStick/M 2GB ME

Description

The CmStick/M 2GB ME is the heart of the CodeMeter Digital Rights Management system as USB device in a very small, noble and rugged metal case. It contains a SmartCard chip including a secure memory of about 60 kbyte available for storing more than 1000 licenses. The basic idea of the revolutionary CodeMeter concept is that licenses can be stored for many products even from many different vendors at the same time. Additionally the CmStick/M offers 2 GB flash memory which can be used as a high speed removable drive.

License Options are: Text (description of an entry), Unit Counter (i.e. number of runs or actually run time of a license), Activation Time (the license is valid from), Expiration Time (the license is valid until), Usage Period (starts at first use), Feature Map (up to 32 modules or versions), License Quantity (concurrent use / floating network licenses), Protected Data / Extended Protected Data (128x256 bytes read-only data), Hidden Data (128x256 bytes only readable with password; usable as secret/private key), Secret Data (128x256 bytes non-readable, only usable as secret/private key), User Data (unsecured 256 bytes), Customer Owned License Information (256 bytes).

Used algorithms: 128 bit AES, SHA-256, 1024 bit RSA, 224 bit ECC.

The used SmartCard chip contains a random number generator according to FIPS140-1 and fulfills EAL 4+ (Common Criteria certified). The CmStick has a green and a red LED.

Technical Specifications

The CodeMeter technology is covered by US 7.145.297 and other patents.

- **Interface:** Hi-Speed USB 2.0 certified, backward compatible with USB 1.1
- **Data retention:** >10 years @ 100k program/erase cycles, using SLC-Nand flash memory, embedded "Dynamic Wear- Leveling" algorithm to have flash data WRITE to be distributed over the storage area and the end product life time will be extended
- **Flash Speed:** up to 15 MByte/s writing, up to 25 Mbyte/s reading
- **Power supply:** 5 V bus-powered, < 100 mA
- **Temperature:** 0...55 degree C, non-condensing
- **MTBF (Mean Time Between Failures):** > 3 Million hours
- **Case/Dimensions:** Noble metal case, 8 mm x 16 mm x 60 mm (without cap 55 mm)
- **Weight:** CmStick 24 g (without cap 19 g)
- **Warranty:** 36 months



Certificates

The CmStick/M 2GB ME is tested and qualified with the following standards:

■ CE-Conformity | European Certificates

Radiated Emissions according to EN 55022/2003 (DIN VDE 0878 Part22, EN 55022:1998 + A1:2000 + A2:2003.

Immunity according to EN55024 (VDE 0878 part 24): 2003-10; EN 55024:1998 + A1:2001 + A2:2003 against: Radiated Radio Frequency (RF) and electromagnetic field

Electrostatic Discharge (ESD), air discharge

Conducted Electromagnetic RF

Fast Transient Bursts

DIN EN 61000-3-2 (VDE 0838 part 2):2001-12; EN 61000-3-2:2000

DIN EN 61000-3-3 (VDE 0838 part 3):2002-05; EN 61000-3-3:1995 + Corr.: 1997 + A1:2001

■ International Certificates

FCC Part 15, Subpart B / VCCI 2003-04 (Japan)

■ Other Certificates

VDE / GS: VDE-Reg-No. 129382

UL C-UL-US listed I.T.E. Accessory 10WB, E-File 211202

The encryption device is only for use with UL listed PCs (low power system). Meets UL 60950-1 and CSA C22.2 No. 60950-1 Safety of Information Technology Equipment.

Listed on USB Integrators List.

All CmStick/M 2GB ME marked as RoHS are fully compliant according to EC Directives 2002/95/EC (RoHS) and 2002/96/EC (WEEE).

SGS testing report CE/2008/B5843, December 2008

Ordering Information

P/N 1011-02-135: CmStick/M 2GB ME bulk

Other memory variants and individual cases or laser engraving on request.

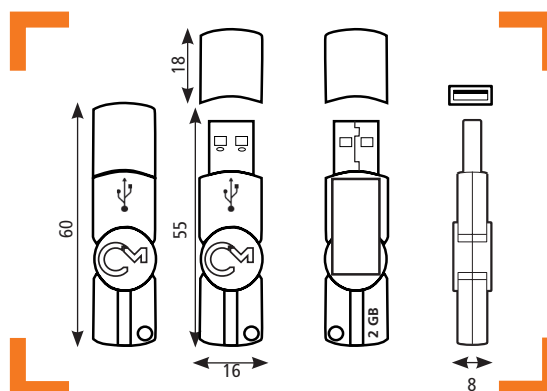

RoHS compliant
WEEE-Reg-No:
DE 90465365

All dimensions in millimeter.
Subject to change without
notice.



WIBU-SYSTEMS AG
Rueppurrer Strasse 52-54
D-76137 Karlsruhe
Tel: +49-721-93172-0
Fax: +49-721-93172-22
info@wibu.com
www.wibu.com

WIBU
SYSTEMS